

# STANDARD CONNECTORIZED AMPLIFIER/MULTIPLIER

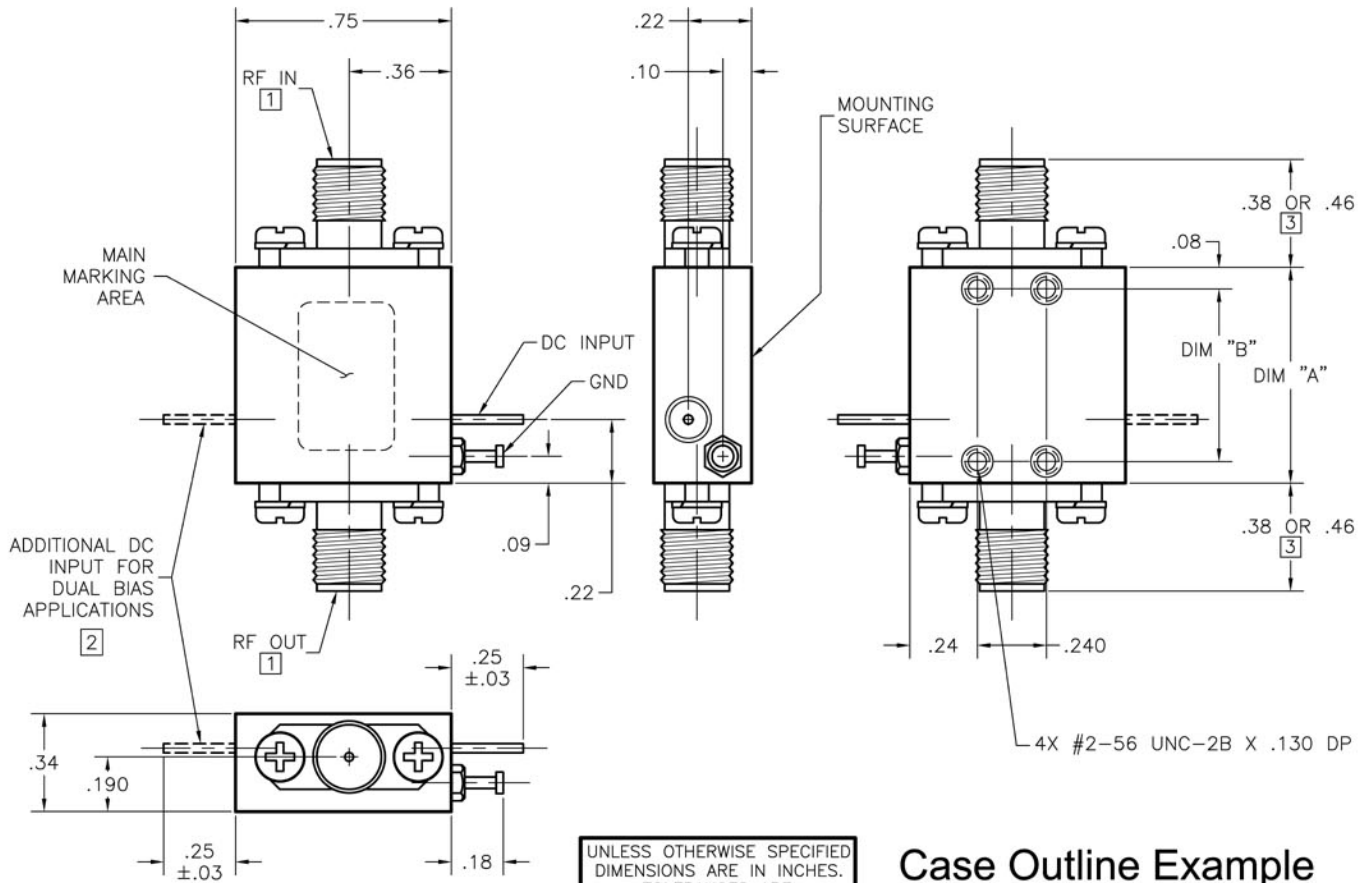

UNLESS OTHERWISE SPECIFIED  
DIMENSIONS ARE IN INCHES.  
TOLERANCES ARE:  
.XX±.02 .XXX±.005

NOTES: (Unless Otherwise Specified)

- 1 RF CONNECTORS ARE SMA, 2.92mm OR 1.85mm FEMALE.
- 2 ONLY USED ON PACKAGE NUMBERS ENDING IN "D".
- 3 CONNECTOR DIMENSIONS:  
SMA & 2.92mm FEMALE ARE .38".  
1.85mm FEMALE IS .46".

Standard Outline Drawing for Cases with Female Connectors. Male Connectors available upon request. Waveguide options are available for Products operating >18 GHz

PACKAGE#	DIM "A"	DIM "B"
__03__	.75	.600
__04__	.95	.800
__05__	1.15	1.000
__06__	1.35	1.200
__07__	1.55	1.400
__08__	1.75	1.600
__09__	1.95	1.800
__10__	2.15	2.000
__11__	2.35	2.200
__12__	2.55	2.400
__13__	2.75	2.600
__14__	2.95	2.800
__15__	3.15	3.000

## Case Outline Example

